

# SULLAIR TWO-STAGE

## Rotary Screw Air Compressors

Constant Speed and Variable Speed Drives (VSD)

112–450 kW | 150–600 hp



**SULLAIR**<sup>®</sup>

*Always air. Always there.*<sup>®</sup>

# ABOUT SULLAIR

For more than 50 years, Sullair has been on the leading edge of compressed air solutions. We were one of the first to execute rotary screw technology in our air compressors. And our machines are famous all over the world for their legendary durability. As the industry moves forward, Sullair will always be at the forefront with quality people, innovative solutions, and air compressors that are built to last.

*Sullair was founded in Michigan City, Indiana in 1965, and has since expanded with a broad international network to serve customers in every corner of the globe. Sullair has offices in Chicago and manufacturing facilities in the United States and China — all ISO 9001 certified to assure the highest quality standards in manufacturing. In addition, the Sullair Suzhou facility is ISO14001 and OHSAS 18001 certified.*

## SULLAIR CAPABILITIES

### **SULLAIR LEADERSHIP**

Since 1965, Sullair has been recognized around the world as an innovator and a leader in rotary screw compression and vacuum technology. For more than 50 years, Sullair has designed and manufactured its own rotors and air end assemblies in Michigan City, Indiana.

The legendary rotary screw design sets the industry standards and delivers the quality and reliability one expects from a leader.

### **SULLAIR TECHNOLOGY**

Utilizing the most modern technologies, equipment and advanced manufacturing techniques, Sullair designs, manufactures, assembles, and tests the most innovative compressed air and vacuum products in the industry. Sullair products are known around the world for their universally applicable design, outstanding craftsmanship and superior quality.

### **STATISTICAL PROCESS CONTROL**

The Sullair Statistical Process Control (SPC) system monitors rotor quality standards to assure consistent compressor and vacuum performance.

### **COMMITMENT TO INNOVATION**

Underlying leadership at Sullair is a dedication to excellence and a commitment to innovation. Sullair constantly explores new ideas and seeks new ways to meet the industry's need for increasingly energy efficient compressed air and vacuum solutions.

# TWO-STAGE COMPRESSION ADVANTAGES

AT FULL-LOAD

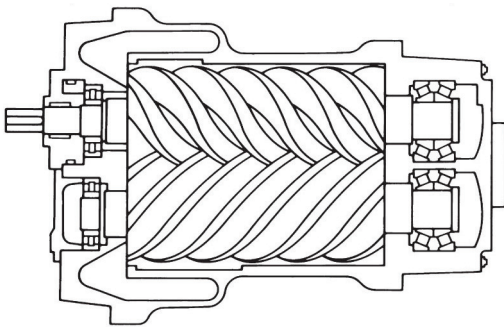

Intake 14.5 psia	Compression Ratio 7.9 to 1	Discharge 114.5 psia
---------------------	-------------------------------	-------------------------

SINGLE-STAGE

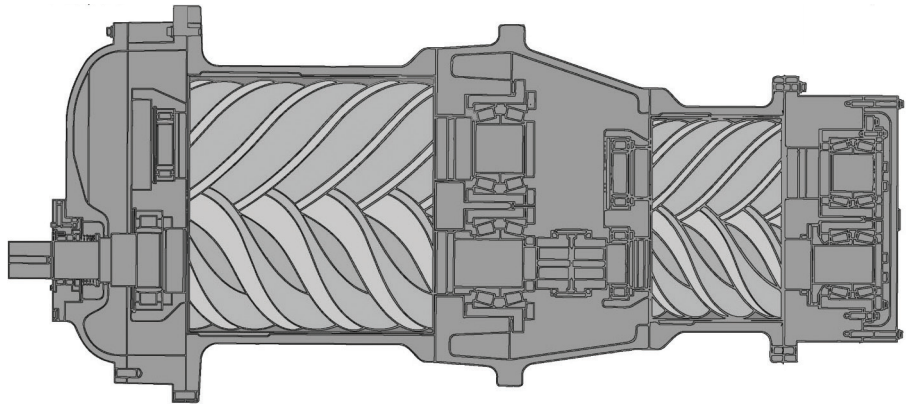

Intake 14.5 psia	Compression Ratio 2.8 to 1	Interstage 41 psia	Compression Ratio 2.8 to 1	Discharge 114.5 psia
---------------------	-------------------------------	-----------------------	-------------------------------	-------------------------

TWO-STAGE

## Up to 15% power savings

Compared to equally sized single-stage compressors, two-stage compressors offer a 12–15%\* power advantage.

### Why?

- Compression is divided between two stages resulting in power savings
- Reduced differential pressure across each stage minimizes internal leakage losses

**Example:** A single-stage compressor located at sea level and operating at 100 psig has a 7.9 to 1 compression ratio (in absolute terms).

A two-stage compressor operating at the same altitude and pressure has a 2.1 to 1 compression ratio per stage.

## Setting the industry standard since 1984 with a superior end-to-end design

- Unique rotor arrangement engineered for maximum efficiency compared to other two-stage configurations
- Unmatched full-load efficiency—energy savings investment payback in a quickly as two years compared to single-stage compressors

### Capacity Control Options

Match compressed air supply with demand.

- Spiral Valve
- Variable Speed Drive (VSD)

## Rotary Screw Reliability

Two-Stage Series tandem compressors use a two-stage rotary screw air end, featuring the Sullair rugged bearing design:

- Tapered roller bearings on the discharge end
- Cylindrical roller bearings on the inlet for high load carrying capacity

**Dividing compression across two stages also extends bearing life.**

### Broad Operating Range

**Power:** 150–600 hp (112–450 kW)

**Delivery:** 590–3000 acfm (16.7–84.9 m<sup>3</sup>/min)

**Pressure:** 100–175 psi (6.8–12 bar)

### Two-Stage Extreme Pressure models available

**Power:** 200–500 hp (149–373 kW)

**Delivery:** 500–1350 acfm (14.2–37.8 m<sup>3</sup>/min)

**Pressure:** 225–500 psi (15.5–34.5 bar)

\* Compressed Air and Gas Handbook [Sixth Edition]

# POWER SAVINGS PER 1000 CFM ON TS-32

## Two-Stage Tandem vs Single-Stage Rotary Screw

### At Full-Load

At a power cost of \$.08/kW/hr, the black dotted line illustrates a tandem two-stage compressor will save \$14,373 per 1000 cfm over a single-stage compressor operating for 8000 hours at 100 psig.

At a power cost of \$.12/kW/hr, the green dotted line shows a \$21,560 savings per 1000 cfm over a single-stage compressor operating for 8000 hours at 100 psig.

Potential savings may be significantly higher for larger capacity compressors.

Energy Savings Two-Stage over Single-Stage, Full-Load

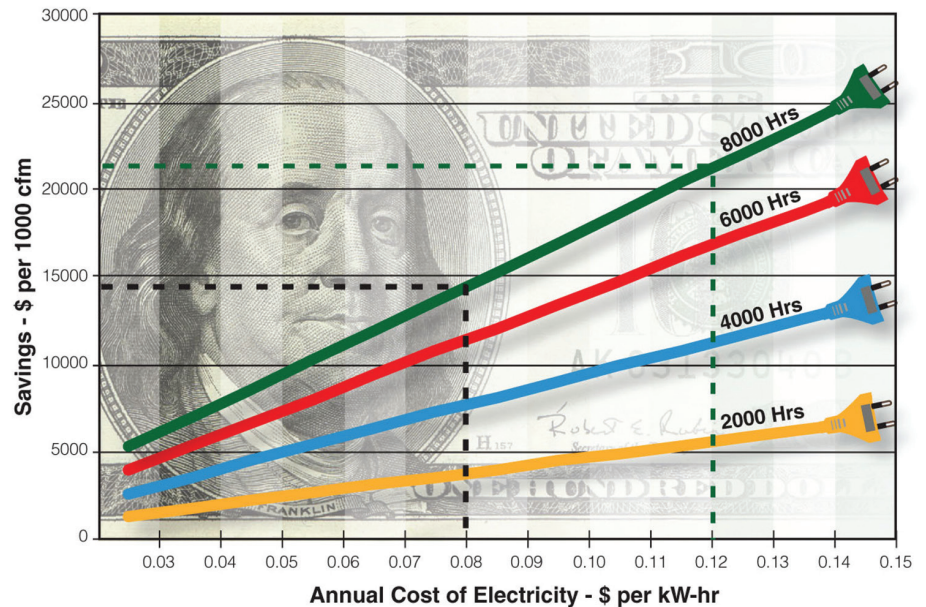

## LEGENDARY SULLAIR AIR END

Decades of proven reliability are testimony to the quality of the Sullair air end. Although the principle of rotary screw compression remains the same, Sullair continually improves materials, engineering and design of its air ends and compressor packages.

### Longer Air End Life

Sullair air ends have only two moving parts: the asymmetrical profile rotors. Contact occurs only on a lubricated pitchline, so wear is virtually eliminated. As a result, Sullair compressors do not lose capacity or efficiency.

### No Loss of Capacity or Efficiency

Controlled pressure lubrication and Bearing Fluid Reservoirs (BFR) assure a reliable supply of fluid to rotating elements.

### Lower Operating Costs

Discharge port matches ratios of volume and operating pressure for maximum efficiency. Axial air inlet avoids preheating inlet air for further savings.

# SULLAIR TWO-STAGE COMPRESSORS

TS-20, TS-32 AND TS-32S

## 1. Multi-Stage Air-Fluid Separation

- Dual nested Optimizer™ separator elements, reduce fluid carryover to a maximum of 1 ppm
- Reduced carryover lowers make-up fluid costs
- Pleated Optimizer elements lower initial pressure drop for greater efficiency and extends element life
- Easy to change with built-in lid lifting device

## 2. Fiberglass Fluid Filter

- Aircraft-quality media provides better filtration
- Up to 20% more efficient than conventional paper elements
- Lengthens life of the compressor

## 3. Optimalair® Heavy-Duty Air Intake Filter

- Includes remote air intake connection
- Provides finest inlet filtration in the industry (0.4 microns using Fine Fiber Technology)
- Keeps fluid clean and extends life of other internal components
- Reduces pressure drop throughout the operating life, resulting in energy savings

## 4. Two-Stage Compressor Air End

- Delivers more air
- Reduces power consumption
- Extends air end bearing life

## 5. Enhanced Serviceability for Air-Cooled Oil Cooler and Aftercoolers

- Easy to remove panels provide access for cleaning coolers

## 6. Motor Coupled to Air End Through Non-Lubricated, Flexible Coupling

- Allows use of standard NEMA frame motor
- Simplifies installation and start-up

## 7. Variable Capacity Control System Featuring Spiral Valve Technology

- Lowers part-load operating costs
- Reduces cycling duty on package
- Maintains consistent plant pressure
- Simple control
- Reduces bearing load

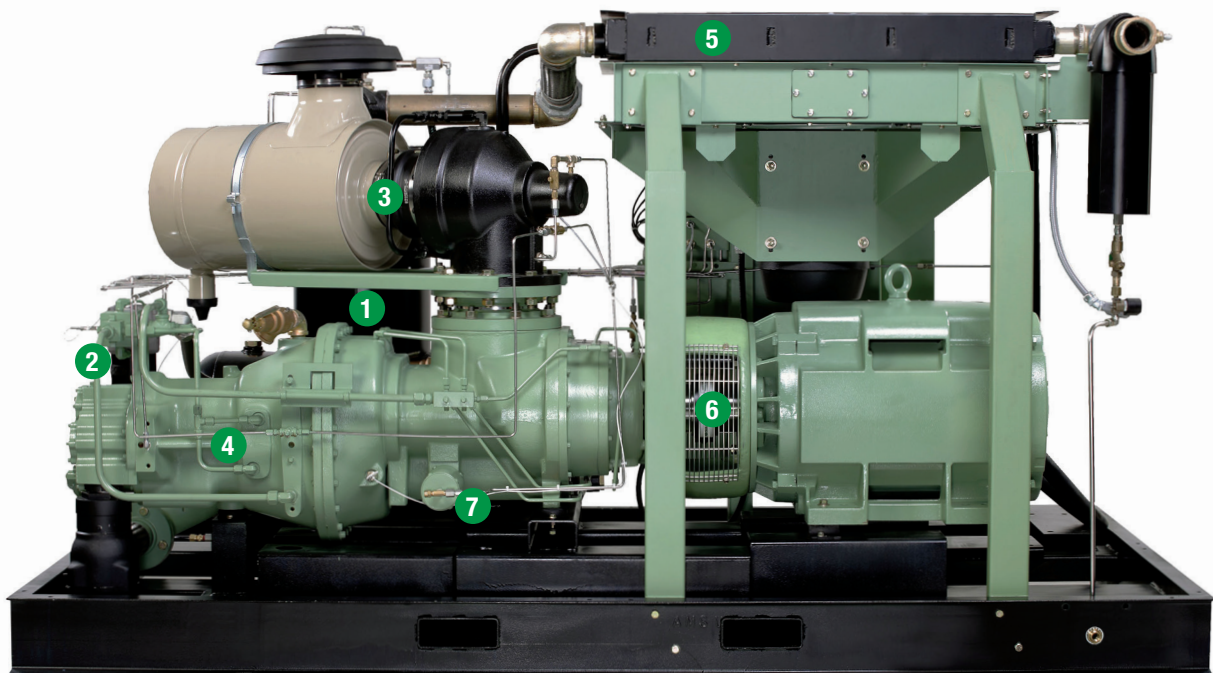

### **Sullair Supervisor™ Controller**

- Computer-compatible microprocessor controller has simple graphic illustration of monitored functions and an easy-to-read keypad
- Constant readout of pressure and temperature
- On-demand readout of all operating and maintenance conditions
- Monitors key functions and safety shutdowns
- Power failure auto restart
- Dual control, provides automatic start-stop operation
- Lead-lag and sequencing with multiple compressors
- Service and preventive maintenance schedule
- Hours are recorded for “Run,” “Loaded” and “Consumable Parts”
- Fault history with sensor readings
- “Help” key provides built-in troubleshooting

### **Easy Maintenance**

- Access to all critical components even with a sound enclosure installed

### **Time Proven End-to-End Design**

- Reduces pressure drop through stages
- Easy serviceability

### **NEMA 4**

- Wye Delta starter for softer start

### **Bearing Fluid Reservoirs**

- Ensure that fluid is available at start-up
- Extend air end life

## **SELECT A LONG-LIFE FLUID**

### **Genuine Sullube® Factory Fill**

- A 10,000-hour extended-life synthetic fluid powered by Dow technology, Sullube has been used in more than 50,000 compressors worldwide

### **Optional PristineFG™**

- Food Grade Designed specifically for compressors used in food, beverage and pharmaceutical applications and meets FDA and USDA H-1 requirements



### **Sullair 10-Year Diamond Warranty**

The Sullair 10-Year Diamond Warranty provides comprehensive protection for Sullair lubricated rotary screw air compressors. This program distinguishes itself by covering all major components for new air compressors (with discharge pressures up to 150 psig):

- 10 years on the air end
- 5 years on the main motor, fan motor, aftercooler, oil cooler, separator vessel, variable speed drive (if equipped)

Maintaining the Sullair 10-Year Diamond Warranty requires using Genuine Sullair parts, Sullube®, and participation in the oil sampling program. Restrictions apply.

# PART-LOAD SAVINGS WITH SULLAIR SPIRAL VALVE

**Fact:** Electric power costs to run an air compressor continuously for one year is often two to three times greater than the compressor purchase price itself.

## Sullair Two-Stage Series with Spiral Valve

By combining two-stage compression and a spiral valve, the TS performs with unmatched full-load and part-load efficiency — often providing a two-year energy savings payback compared to a single-stage compressor.

## Spiral Valve Saves You Power

Compressor displacement is matched to the output need. Spiral Valve technology assures precision operation for virtually any part load point. Thus providing significant power savings at part load conditions compared to compressors using suction throttling, or load/no load control.

**Part-load capacity and efficiency can produce energy savings up to 17%.**

## Built-in Energy Savings

- 13% more efficient at full-load operation compared to single-stage screw compressors
- 30% savings at 60% load compared to single stage screw compressors

## How It Works

Compression volume varies to suit the air demand by progressively opening or closing internal bypass ports on the air end.

Capacity is matched to system demand — reducing cycling time and extending component life.

COMPRESSOR PERFORMANCE COMPARISON

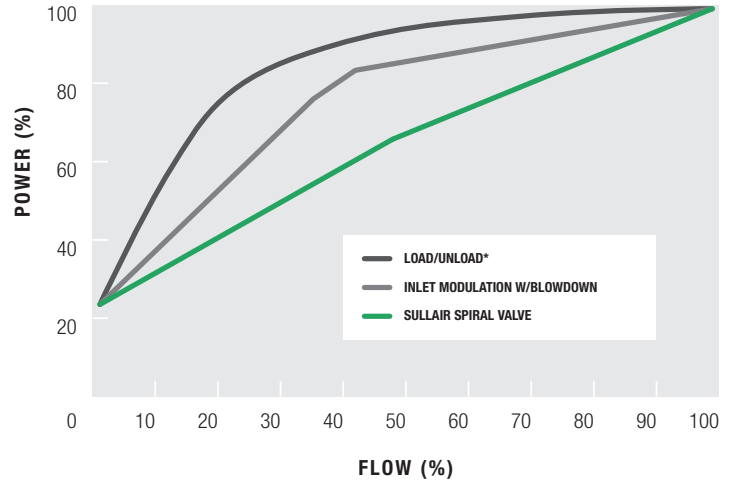

## Match Supply with Demand

By activating automatically when the unit is operating under partial load. This allows compression of only the required quantity of air — allowing greater compression efficiency and reduced power consumption.

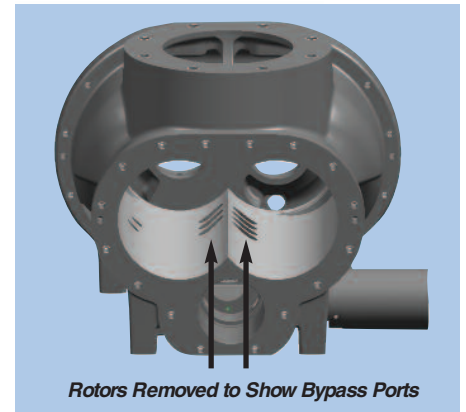

BYPASS PORTS IN STATOR

CLOSED BYPASS PORTS

PARTIALLY OPEN BYPASS PORTS

OPEN BYPASS PORTS

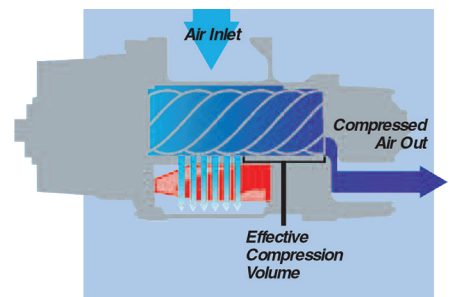
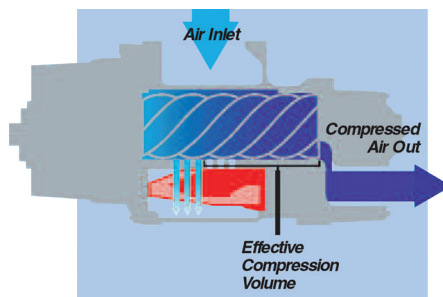
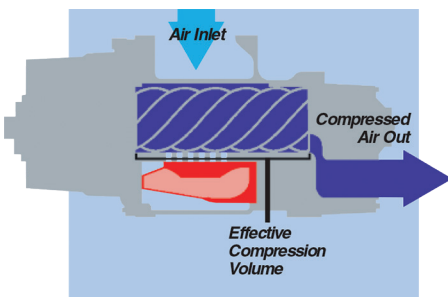

# SULLAIR VARIABLE SPEED DRIVE (VSD) COMPRESSORS WITH SMART TECHNOLOGY

## Compressors with Sullair Smart Technology

*Simplicity. Reliability. System Protection.*

- Excellent energy savings
- Helps prevent potential peak demand charges
  - Sullair Two-Stage Series provides highest power factor over the frequency range — helping avoid utility company penalties
  - Potential utility company rebate
- DC link choke or 3% line reactor included (model/voltage specific)
- Stable system pressure
- Consistent product quality
- Reduced storage requirements
- Flexibility for future growth
- Lowest five-year life cycle cost

## Reliability

- Complete package designed from the frame up — not built with a variety of off-the-shelf components
- Serial communication between the Supervisor™ Controller and VSD eliminates need for hard wired relays

## VSD — SUPERIOR CAPACITY CONTROL

- Stabilizes system pressure — improving process consistency and reducing product rejects
- Increased margins from energy savings

## PART LOAD PERFORMANCE ASSESSMENT

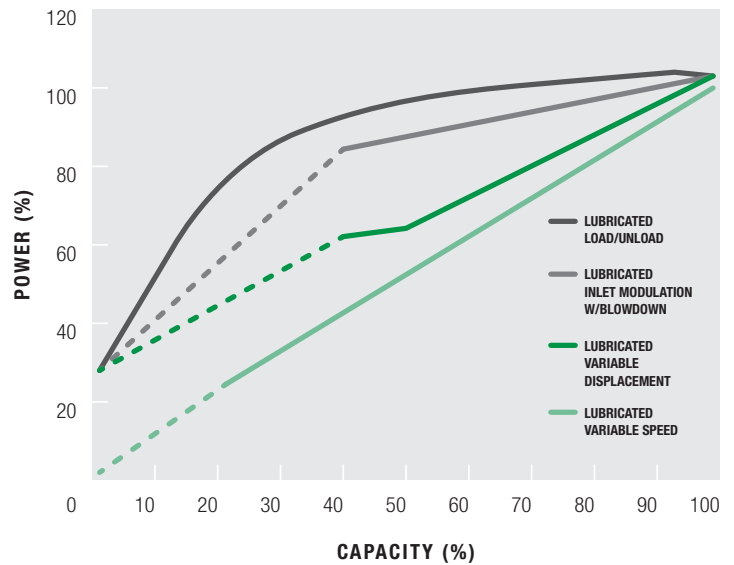

Reference: Compressed Air and Gas Handbook, 6th Edition, pages 221-224.

The chart above is a representation of nominal control systems for generic comparative purposes. A detailed and accurate comparison of specific compressor models is available from your Sullair representative or authorized distributor.

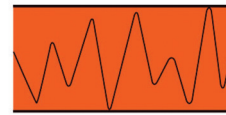

**Conventional System Pressure**



**Sullair Smart Technology System Pressure**

## Maximum Energy Efficiency with Sullair Two-Stage Series

- Legendary air end with low restriction inlet valve
- Optimized fluid system — reducing fluid temperatures
- Premium efficient motors
- Low pressure drop air-fluid separation system
- High-efficiency fan

Considering energy costs represent 82% of the total cost of owning compressors, these savings significantly reduce total life cycle costs.

## Total Compressor Flexibility

Sullair Variable Speed Drive compressors provide flexibility to vary both capacity and pressure — allowing you to grow your air system without adding another compressor.



# SULLAIR STATIONARY AIR POWER SYSTEMS

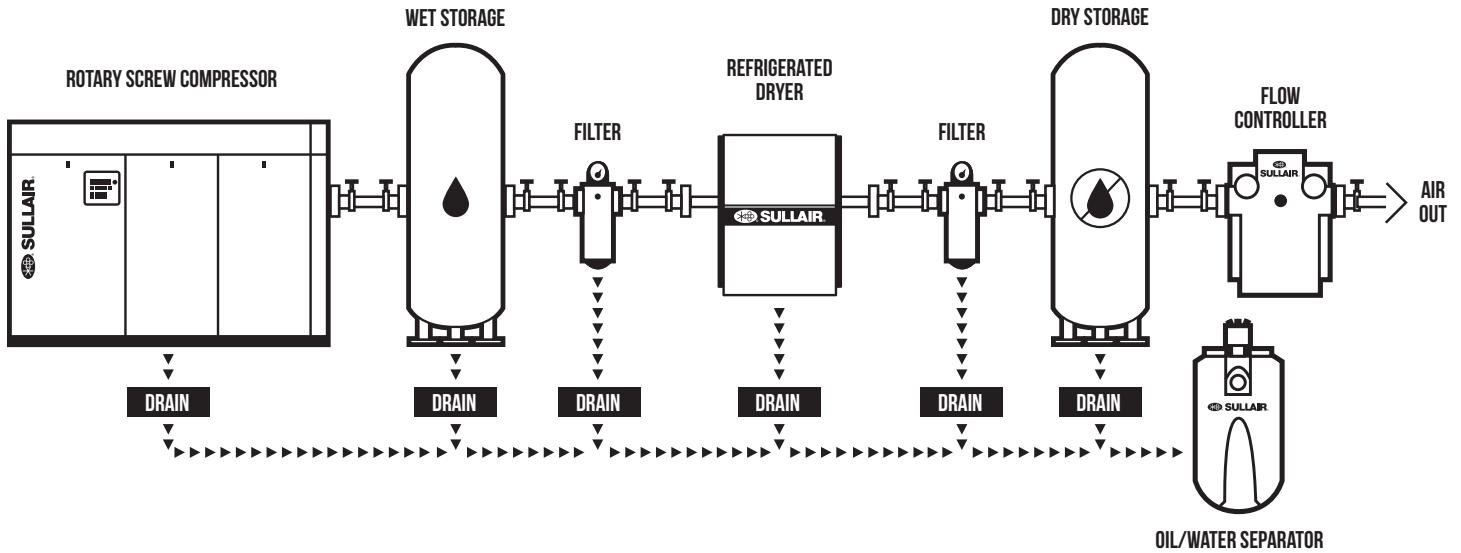

Sullair offers total compressed air systems to help you reduce energy costs and improve productivity by analyzing, managing and controlling your compressed air systems.

Sullair air systems include: plant air audits, energy efficient products, compressed air system controls, equipment to monitor and manage systems, air distribution products, and after-purchase support.

Each component of the system is carefully matched for capacity and pressure to provide maximum performance and energy efficiency.

## The system includes:

- Rotary screw compressor
- Wet storage
- Refrigerated dryer or desiccant dryer
- Filters to meet your requirement
- Dry storage
- Flow controller
- Drains
- Oil/water separator

## Sullair Reduces Your Life Cycle Costs

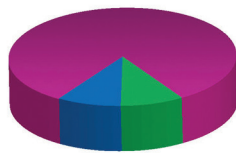

- Equipment
- Maintenance
- Electricity

## Air Compressor Life Cycle Costs

According to *Best Practices for Compressed Air Systems, Compressed Air Challenge* [Second Edition, 2007] energy costs now represent 82% of total operating expenses. Energy savings from Sullair Two-Stage compressors can significantly reduce life cycle costs.

Sullair compressors help significantly reduce operating and energy costs over the entire compressor life cycle. How?

- Legendary Sullair air end with a low restriction inlet valve
- High-efficiency fan
- Low pressure drop air-fluid separation system to prevent energy loss

Extend component life with improved air filtration

- Extended separator life
- Improved fluid filter life
- Less lubricant contamination

## Fluid matters

Genuine Sullube® 10,000-hour fluid helps reduce fluid disposal costs.

# TWO-STAGE EXTREME PRESSURE

HIGH PRESSURE PERFORMANCE. SULLAIR DURABILITY.

200–500 hp | 225–500 psi

## Dependable, high-performance two-stage air end for maximum power savings

### 460v motor coupled to air end via non-lubricated, flexible coupling

- Allows use of Standard NEMA frame motor
- Flange-mounted for positive alignment

### Sullair Supervisor Controller

- Easy pressure adjustment
- Capacity modulation range 100 to 40%

### Heavy-duty inlet air filter

- Two-stage, dry type
  - Inside safety element
  - Differential pressure indicator

### Air-fluid separation

- ASME psi rated tank
  - ASME pressure relief valve
- Pleated air-fluid separator element for lower initial pressure drop

### Cooling

- Air-cooled units use mounted and piped aftercooler with quiet fan
- Water-cooled units feature an air-in-shell, water-in-tube aftercooler design

### Options

- Magnetic starter
- Solid state starter
- Sound attenuating enclosure with removable panels
- 575v



# TECHNICAL SPECIFICATIONS

60HZ MOTOR TWO-STAGE	MOTOR		CONSTANT SPEED DRIVE FULL-LOAD CAPACITY*								LENGTH		WIDTH		HEIGHT		WEIGHT	
			100 PSI acfm	6.8 bar m³/min	125 PSI acfm	8.6 bar m³/min	150 PSI acfm	10.3 bar m³/min	175 PSI acfm	12 bar m³/min	in	mm	in	mm	in	mm	lbs	kg
TS-20-150	150	112	826	23.3	763	21.6	680	19.2	616	17.4	120	3048	72	1828	68	1727	7350	3334
TS-20-200	200	149	1051	29.7	960	27.1	868	24.5	820	23.2	120	3048	72	1828	68	1727	7350	3334
TS-20-250	250	186	1200	33.9	1132	32.0	1035	29.3	960	27.1	120	3048	72	1828	68	1727	7350	3334
TS-32-200	200	149	1105	31.2	-	-	-	-	-	-	154	3911	78	1981	86	2184	12,720	5770
TS-32-250	250	186	1335	37.8	1240	35.1	1100	31.1	-	-	154	3911	78	1981	86	2184	12,720	5770
TS-32-300	300	224	1640	46.4	1440	40.7	1330	37.6	1240	35.1	154	3911	78	1981	86	2184	12,720	5770
TS-32-350	350	261	1875	53.01	1733	49.0	1575	44.6	1440	40.7	154	3911	78	1981	86	2184	12,720	5770
TS-32S-400	400	298	2220	62.8	1943	55.0	1681	47.6	-	-	175	4445	84	2134	92	2337	15,900	7212
TS-32S-450	450	336	2350	66.5	2135	60.4	1943	55.0	-	-	175	4445	84	2134	92	2337	15,900	7212
TS-32S-500	500	373	2530	71.6	2350	66.5	2220	62.8	-	-	175	4445	84	2134	92	2337	15,900	7212
TS-32S-600	600	447	3000	84.9	2700	76.4	2530	71.6	-	-	175	4445	84	2134	92	2337	15,900	7212
60HZ MOTOR TWO-STAGE	MOTOR		VARIABLE SPEED DRIVE FULL-LOAD CAPACITY*								LENGTH		WIDTH		HEIGHT		WEIGHT	
			100 PSI acfm	6.8 bar m³/min	125 PSI acfm	8.6 bar m³/min	150 PSI acfm	10.3 bar m³/min	175 PSI acfm	12 bar m³/min	in	mm	in	mm	in	mm	lbs	kg
V-320TS-250	250	186	1300	36.8	1180	33.4	1050	29.7	-	-	154	3911	78	1981	86	2184	12,720	5770
V-320TS-300	300	224	1550	43.8	1400	39.6	1250	35.4	-	-	154	3911	78	1981	86	2184	12,720	5770
V-320TS-350	350	261	1800	50.9	1645	46.5	1480	41.9	-	-	154	3911	78	1981	86	2184	12,720	5770
V-320TS-400	400	298	2075	58.7	1870	52.9	1695	48.0	-	-	175	4445	84	2134	92	2337	15,900	7212
V-320TS-450	450	336	2310	65.4	2100	59.4	1900	53.8	-	-	175	4445	84	2134	92	2337	15,900	7212
50HZ MOTOR TWO-STAGE	MOTOR		CONSTANT SPEED DRIVE FULL-LOAD CAPACITY*								LENGTH		WIDTH		HEIGHT		WEIGHT	
			100 PSI acfm	6.8 bar m³/min	125 PSI acfm	8.6 bar m³/min	150 PSI acfm	10.3 bar m³/min	175 PSI acfm	12 bar m³/min	in	mm	in	mm	in	mm	lbs	kg
TS-20-150	150	112	786	22.3	720	20.4	647	18.3	590	16.7	120	3048	72	1828	68	1727	7350	3334
TS-20-200	200	149	990	28.0	927	26.3	847	24.0	778	22.0	120	3048	72	1828	68	1727	7350	3334
TS-32-200	200	149	1090	30.9	-	-	-	-	-	-	154	3911	78	1981	86	2184	12,720	5770
TS-32-250	250	186	1357	38.4	1183	33.5	1090	30.9	1021	28.9	154	3911	78	1981	86	2184	12,720	5770
TS-32-300	300	224	1660	47.0	1430	40.5	1300	36.8	1183	33.5	154	3911	78	1981	86	2184	12,720	5770
TS-32-350	350	261	1845	52.3	1660	47.0	1556	44.1	1430	40.5	154	3911	78	1981	86	2184	12,720	5770
TS-32S-400	400	298	2100	59.5	1942	55.0	-	-	-	-	175	4445	84	2134	92	2337	15,900	7212
TS-32S-450	450	336	2240	63.4	2100	59.5	1942	55.0	-	-	175	4445	84	2134	92	2337	15,900	7212
TS-32S-500	500	373	2480	70.2	2240	63.4	2100	59.5	-	-	175	4445	84	2134	92	2337	15,900	7212
TS-32S-600	600	447	2900	82.1	-	-	2480	70.2	-	-	175	4445	84	2134	92	2337	15,900	7212

\* Capacity per CAGI / PNEUROP PN2CPTC2 (Annex C to ISO 1217)

Information and data are subject to change without notice.

# TECHNICAL SPECIFICATIONS

## TWO-STAGE EXTREME PRESSURE

60HZ MOTOR TWO-STAGE	MOTOR	CAPACITY	FULL-LOAD PRESSURE	LENGTH	WIDTH	HEIGHT
Model	hp	acfm	psi	in	in	in
LS-20T-500/250	200	500	250	120	72	74
LS-20T-500/350	200	500	350	120	72	74
LS-20T-630/225	200	630	225	120	72	74
LS-20T-630/350	250	630	350	120	72	74
LS-20T-750/250	250	750	250	120	72	74
LS-20T-300-630/500	300	630	500	120	72	74
LS-20T-350-750/500	350	750	500	120	72	74
LS-20T-750/350	300	750	350	120	72	74
LS-20TS-800/225	300	800	225	185	81	80
LS-20TS-800/325	300	800	325	185	81	80
LS-20TS-800/350	350	800	350	185	81	80
LS-20TS-960/225	300	960	225	185	81	80
LS-20TS-960/300	350	960	300	185	81	80
LS-20TS-960/350	400	960	350	185	81	80
LS-20TS-1250/300	450	1250	300	185	81	80
LS-20TS-1350/300	500	1350	300	185	81	80

For more information, contact your local authorized Sullair distributor.